

This .Pdf document is for informational purposes only and contains an Installation Template. The Template in this .Pdf document is not to scale. Do not use for sizing purposes.

Continue to next pages for Template instructions, Owners Guide, Humidistat Instructions.

ATTACH TEMPLATE TO VERTICAL SIDE SURFACE OF FURNACE PLENUM MODEL HDT2600 HUMIDIFIER MOUNTING TEMPLATE

▲ DANGER: MAKE SURE YOU ARE NOT CUTTING OR DRILLING INTO ANY AIR CONDITIONING ELECTRICAL ACCESSORIES DURING INSTALLATION

▲ CAUTION: This template must be level from side to side and front to back before drilling or cutting.

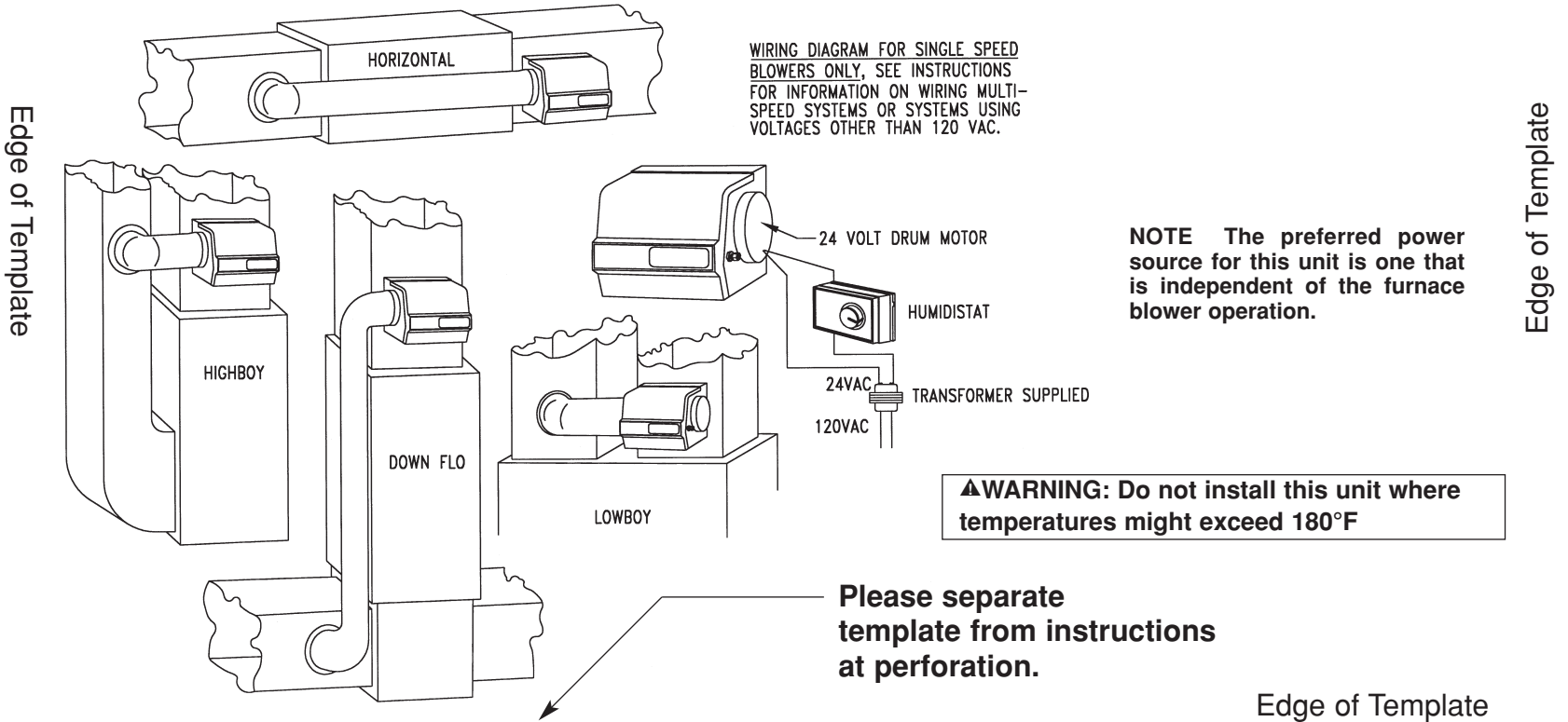

UNIT IS EASILY REVERSIBLE FOR RIGHT OR LEFT HAND INSTALLATION. READ INSTRUCTIONS COMPLETELY BEFORE BEGINNING INSTALLATION.
▲ CAUTION: DO NOT INSTALL WHERE FREEZING TEMPERATURES COULD OCCUR.
WHEN INSTALLING UNIT IN AREAS THAT WATER DAMAGE COULD RESULT IN THE EVENT OF A OVERFLOW, INSTALL A SUITABLE SAFETY CATCH PAN PLUMBED TO A DRAIN.

NOTE: If the system contains a multi-speed blower motor, it is necessary to isolate the humidifier transformer to prevent premature burn out caused by the inductive current produced by the motor during high speed operation. This can be accomplished by many different types of wiring and accessories, such as using a pressure sensor or fan sail switch (to detect blower operation) and using an independent electrical circuit to power the humidifier transformer.
▲ CAUTION: You must comply with all local codes, ordinances and regulations pertaining to plumbing and electrical wiring.

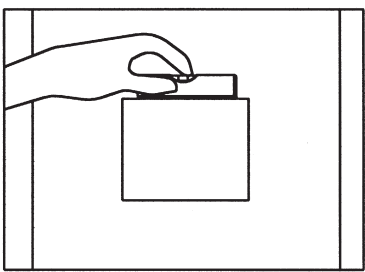

1. After determining the best location for the humidifier draw a level line on the plenum and tape the template in position. Trace around the template, then remove template and connect any blank spaces where the tape was removed. Now carefully cut the rectangular opening.

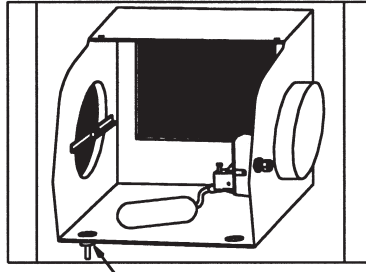

2. Insert cabinet in opening and making sure it is level, mark the location of 5 mounting holes. Remove cabinet and drill 5 7/64" mounting holes. Start the 1" sheet metal screws in the top holes and place the cabinet over the screws and tighten, now secure cabinet at the bottom with two 1/2" screws.

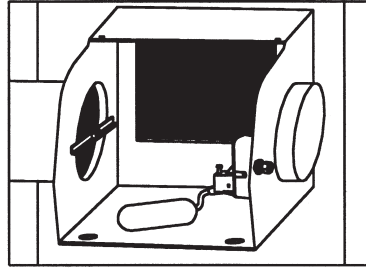

3. On the inside of the cabinet where the bypass tube will connect, snap the bearing bracket in place with the "U" shape of the bracket pointing up. On the opposite side snap the motor plate in place making sure the motor coupling is toward the top. Install the motor cover by placing the lead wires thru the hole in the bottom and snap the cover in place.

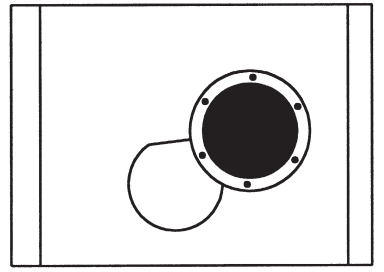

4. Install the 6" collar on the other plenum and connect the 6" bypass tubing from the collar to the unit with sheet metal screws and seal connections with duct tape. If the furnace has air conditioning install the duct damper for summer season shut off.

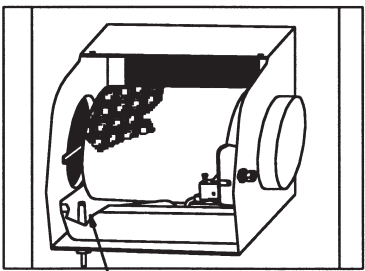

5. Insert the drain fitting in the bottom of the cabinet so that the overflow tube will be toward the front and on the same side as the by-pass tubing. Place the water pan in the unit with the overflow tube over the drain fitting previously installed. Attach 3/8" I.D. tubing to the drain fitting and route continuously downward to a suitable waste drain for overflow protection. Screw the float onto the valve assembly and attach the valve to the unit on the same side as the motor and insert the valve hole plug in the double "D" hole on the opposite side from the valve.

See the orange card in the units parts bag for correct valve & water tubing installation.

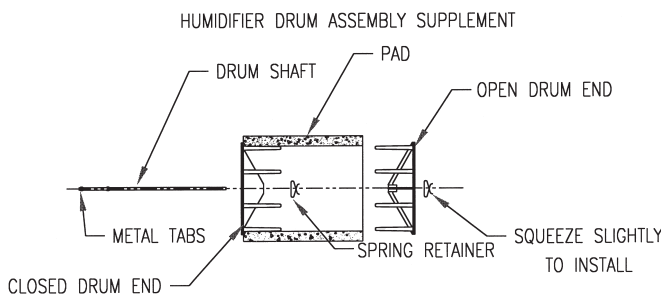

6. Assemble the drum and evaporator pad as shown and install by inserting it into the motor coupling end first then snapping it into the bearing end.

7. Install the saddle valve (using the instructions on the bag) on the nearest cold water pipe. Connect tubing and route it to the humidifier making sure to avoid contact with hot surfaces and sharp edges. Make connection to the humidifier valve as shown on the orange card in the parts bag.

8. Turn water on at saddle valve and adjust the water level to 1-3/8" deep by turning the adjustment screw on the valve clockwise to lower and counterclockwise to raise.

9. Mount the transformer to the location selected and wire the 120 volt side using caution that the power supply is turned off before beginning. Wire the drum motor, transformer, and humidistat as shown on the mounting template wiring diagram.

10. The humidistat supplied is a universal duct or wall mount type unit follow the instructions supplied in the units part bag for locating the humidistat and installation.

Refer to the Maintenance Instruction for proper operating testing and make final adjustments before completing the installation.

 **WHITE-RODGERS**

Comfort --- **plus™**

MODEL HDT2600
WHOLEHOUSE CENTRAL HUMIDIFIER

OWNER'S MANUAL

**Includes Safety, Operating and Maintenance
Instructions**

**CAUTION: READ THESE INSTRUCTIONS THOROUGHLY
BEFORE SERVICING**

FILL IN FOR HOME OWNER REFERENCE:

Model No. _____ **HDT 2600** _____

Installation Date _____

SAVE THIS MANUAL FOR FUTURE REFERENCE



CONTENTS

	PAGE
Principle Of Operation1
Operating Instructions1
Checking For Proper Operation2
Water Hardness & Maintenance2
Maintenance For HDT26003



WARNING: Setting your humidity control higher than the listed setting could cause condensation that would damage your home. If excessive moisture appears on windows or walls, reduce humidity setting at humidistat enough to eliminate condensation. If the situation continues, turn off water valve and the humidistat until condensation is gone.

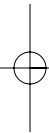

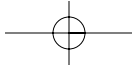

PRINCIPLE OF OPERATION

Your White-Rodgers Humidifier uses the same natural methods of evaporation that you see in mother natures, everyday, normal, environment. Natures way is simple, a little water spread over a large area with a warm breeze will evaporate the water and raise the relative humidity, just the same as it would after a summer shower.

The humidifier accomplishes this with a polyurethane foam evaporator pad that lifts water from the water pan and into the warm air stream. You will notice that the evaporator pad has many holes and connecting strands, these drastically increase the area that the water can evaporate from. This combined with the warm air in your heating system is what makes the humidifier work.

The system is controlled by a humidistat that monitors the relative humidity within your home and activates or deactivates the humidifier accordingly.

Water evaporated from this humidifier leaves behind all the impurities (Calcium, Iron, Lime, Bacteria, etc.) that were contained in the water, thus the vapor is in a pure form and these impurities are not distributed into your home. This will keep our home clean and your family safe from these contaminates.

OPERATING INSTRUCTIONS

Your new humidifier is controlled by a humidistat that is installed either on the cold air return or in the living area on an interior wall. The recommended settings on this control may seem a bit strange when you first read them. But there is a reason for them and it can be explained fairly easily. You will notice the recommended setting goes down with the outdoor temperature, this seems illogical. If you remember last summer when you were outdoors with a cold drink the outside of the container became wet and water began to run down the sides. This is called condensation, caused by the surface of the container reaching the dew point. This means the air surrounding the container contained humidity and the cold surface of the container cooled the air around it, when cooled the air becomes smaller and is no longer capable of holding as much moisture as it could hold when it was warm. This is what caused the moisture to accumulate and run down the container. The same thing can happen in your home in the winter when the outside temperature drops and the inside is warm and humid. This is why the settings go downward when the temperature goes down to prevent accumulation on your windows etc.

At Outside Temperature	Recommended Setting	At Outside Temperature	Recommended Setting
-20°F. -29°C.	15%	+10°F. -12°C.	30%
-10°F. -23°C.	20%	+20°F. - 7°C.	35%
0°F. -18°C.	25%	Above 20° -7°C.	40%

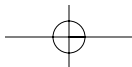

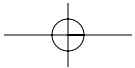

Occasionally some indoor activity may cause the humidity to rise to excess and begin to accumulate on windows. Such activities as cooking, showers, and clothes drying, etc. If this condition persist for more than a few hours the humidifier should be turned off and if this condition still continues, the home should be ventilated to remove the moisture.

CHECKING THE HUMIDIFIER FOR PROPER OPERATION

To check the humidifier for proper operation, winter start up, and after servicing follow this recommended procedure.

1. Turn the water on at the saddle valve to the humidifier.
2. Check the water level in the humidifier, water level setting should be 1-3/8". Turn valve adjustment screw clockwise to lower water level and counter clockwise to raise.
3. Turn the humidistat to its highest setting and observe the humidifier evaporator pad for rotation. If the unit is not rotating turn the furnace on by setting the thermostat higher until the furnace starts and the blower is running.

NOTE: Wiring the unit to operate independent of or in conjunction with the furnace blower is left to the discretion of the installer. On installations where the unit might be closely sized, independent operation allows the unit to operate thru-out the full blower cycle, thereby eliminating lag time involved in starting the humidifier.

4. Reset thermostat and humidistat to their correct positions for automatic operation.

WATER HARDNESS AND MAINTENANCE SCHEDULE

Your humidifier will accumulate minerals such as calcium and lime after operating for a short period (accumulation of minerals is a sure sign the humidifier is producing humidity). The amount of accumulation is dependent on the hardness of the water supply in your area. Therefore the time between cleaning is unpredictable. In areas with hard water where cleaning becomes frequent we suggest installation of a White-Rodgers Automatic Flushing Timer to increase time between cleaning intervals.

NOTE: Excessive buildup of these minerals is detrimental to internal parts as well as evaporative efficiency.

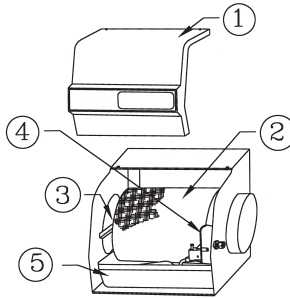

MAINTENANCE INSTRUCTIONS
FOR
WHITE-RODGERS HUMIDIFIER MODEL HDT2600

MODEL HDT2600

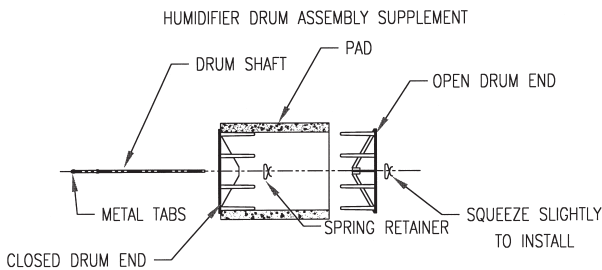

**REPLACEMENT PAD #
A04-1725-034**

1. Turn the water off at the saddle valve by turning the T handle clockwise.
2. Remove the humidifier cover (1) by lifting the bottom upward on the bottom for the model HDT2600.
3. Remove the drum assembly (2) by lifting the drum shaft from the bearing end (3) and slide it out of the motor coupling, then remove drum from unit.
4. Remove the rubber valve seat by grasping it between your thumb and fore finger and lifting it upward and removing it from the valve. (see arrow 4 inside water valve opening.)
5. Now raise the float up to remove the water pan (5) for cleaning.
6. For drum disassembly and assembly see the drawing below.



7. Clean all parts in a 50% solution of vinegar or a humidifier cleaner and water. Soaking over night to remove stubborn deposits, is sometimes required.

NOTE: It is suggested that the evaporator pad be replaced yearly. Depending on the hardness this interval could vary.

8. For reassembly reverse procedures 1 thru 5 and return to the section labeled "CHECKING THE HUMIDIFIER FOR PROPER OPERATION" follow these steps to assure proper humidity output.



 **WHITE-RODGERS**
Controlling Indoor Comfort Worldwide
Since 1937

St. Louis, Missouri Markham, Ontario
314-577-1300 905-201-4701
www.white-rodders.com



The Emerson logo is a trademark and a service mark of Emerson Electric Co.

WIRING INSTRUCTIONS

⚠ CAUTION:

- * Use the wiring diagram shown for single-speed blower operation only.
- * *When wiring multi-speed blower systems use an A50 relay or a fan sail switch to prevent premature component failure.*
- * Consult the instructions included with the humidifier and any additional controls for instructions on wiring.
- * Fatal electrocution is possible if you contact a live wire.
- * Electrical power can cause electrical shock.
- * Disconnect all electrical power supplied to the equipment before beginning installation.
- * All electrical wiring must comply with codes and ordinances.

⚠ **Caution:** *When wiring a Model HFT2900FP or a Steam Humidifier Consult the Units wiring diagram. These Units Don't require an additional transformer.*

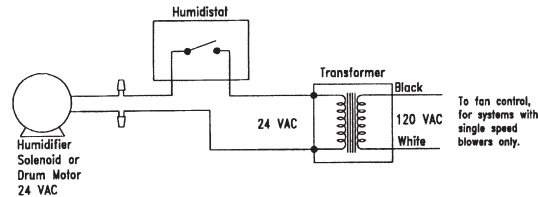

Figure 3: Wiring Diagram

OPERATIONS CHECK

- 1 Turn the heating system thermostat up and wait until the system blower activates.
- 2 Turn the humidistat clockwise to the on position; visually check humidifier for operation.
- 3 Turn the humidistat counterclockwise to 10% or lower; visually check to see that humidifier shuts off.
Note: The set point where the humidistat turns on and off may not represent the actual indoor relative humidity, due to storage and transport environments. Allow at least 24 hours for humidity control to adjust to the installation.
- 4 Turn the humidistat to the recommended setting for operation (see the recommended settings chart on page 1).
- 5 Turn the system thermostat back to normal operation.

⚠ **WARNING:** Adjusting the humidity control higher than the recommended setting may cause condensation resulting in possible damage to the home.

WHITE-RODGERS
Controlling Indoor Comfort Worldwide
Since 1937
www.white-roddgers.com

WHITE-RODGERS

Comfort
plus™

2271-100 HUMIDISTAT

The humidistat is designed for either return air duct or wall mounting. Packaged in a duct mount configuration, (For this type mounting begin installation at the section labeled return air duct installation on page 2.) for conversion to a wall mount configuration simply pull off the knob and remove the mounting screws and rotate the control 180° and reattach the mounting base, (For this type mounting begin installation at the section labeled wall mount installation on page 3.).

⚠ DANGER

- * Do not cut or drill into any air-conditioning or electrical accessories during installation.
- * Fatal electrocution is possible if you contact a live wire.
- * Electrical power can cause electrical shock.
- * Disconnect all electrical power supplied to the equipment before beginning installation.
- * Blindness can occur if freon contacts your eyes.

⚠ CAUTION

- * Do not install on any electrical system over 30 VAC.

⚠ CAUTION

- * All electrical wiring should comply with codes and ordinances.

Recommended Settings

At Outside Temperatures	Recommended Setting
-20°F -30°C	15% (Low)
-10°F -25°C	20% (Low)
0°F -20°C	25% (Med)
+10°F -10°C	30% (Med)
+20°F -5°C	35% (High)
Over 20°F Over 0°C	40% (High)

⚠ WARNING:

Adjusting the humidity control higher than the recommended setting may cause condensation resulting in possible damage to the home.

RETURN AIR DUCT INSTALLATION

- 1 Locate the humidistat in the return air duct at least 12 in. up stream prior to the humidifier or the humidifier by-pass tube.
- 2 Remove the backing and adhere the humidistat mounting template in a horizontal position, make sure it is level.
- 3 Drill four 7/64 in. mounting holes.
- 4 Drill 1/2 in. hole in the center of the template and use tin snips to cut the rectangular hole designated by the dotted lines then remove template.
- 5 Remove the backing and adhere the gasket over the opening area.
- 6 Connect the low voltage wires to the humidistat terminals. Tuck the wire into the recessed area on the back of the base plate.
- 7 Use sheet metal screws to securely fasten the humidistat to the return air duct.

⚠ CAUTION:

- * **Mount the humidistat in the return air duct only, installation on the warm air duct will destroy humidistat element.**
- * **Make certain the wires stay in the slot under the mounting base.**

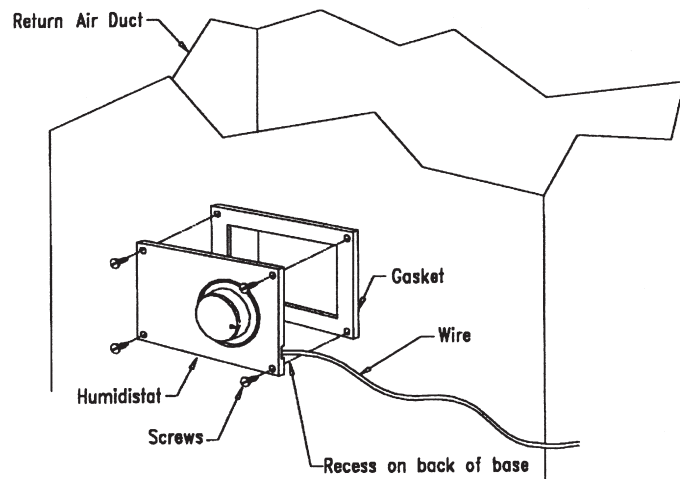

Figure 1: Wiring Diagram

WALL MOUNT INSTALLATION

- 1 Locate the humidistat about 5 ft. above the floor, on an inside wall, away from discharge registers. Also, avoid areas with extreme variation in relative humidity levels; i.e. bathrooms and kitchens. When wall mounting, homeowners usually prefer the humidistat mounted beside, or in the vicinity of the heating thermostat.
- 2 **For conversion to a wall mount configuration, simply pull the indicator knob off and remove the mounting screws, and rotate the control 180° and reattach the mounting base Fig 2.**
- 3 Drill a 3/8 in. hole in the indentation on the mounting base plate.
- 4 Place the base assembly in the predetermined location on the wall, in a horizontal position, make sure it is level. Mark and drill a 3/8 in. hole in the wall.
- 5 Run low voltage wire to the location and pull about 6 in. of wire through the hole.
- 6 Plug the hole with nonflammable insulation to prevent drafts from affecting the humidistat operation.
- 7 Position the base assembly over the wire and pull the wire through the hole previously drilled in the plate.
- 8 Use four 1 in. screws to secure the mounting base plate to the wall.
- 9 Connect the wires to the terminals on the control.
- 10 Use one 3/8 in. screw to secure the humidistat cover.
- 11 Remove the backing and adhere the cover label to the recessed area on the front of the cover.
- 12 Push the indicator knob onto the control shaft.

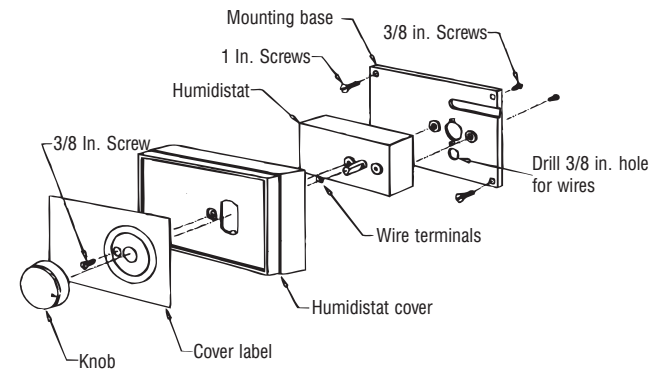

Figure 2: Wall Mounting Diagram